

Specification Summary – ET2-24.4

- 6 Star WELS
- Watermark
- High arch swivel spout highly suitable for Commercial use
- Basin Mounted
- Height approx. 256mm from base of tap to top of arch
- Clearance of approx. 183mm from outlet to base of tap
- Popular option for Utility, Clinical & Food preparation areas or where large containers need to be filled
- Hygienic no touch operation
- No fixed run time for maximum water saving
- Confirmation time of 1-2 seconds
- Auto off after 1 minute if sensor obstructed
- Self-adjusting forward-facing sensor
- Normally suitable for use with stainless steel sinks/troughs
- Battery only or mains power with battery back-up
- Water pressure range between 100-500kPa
- Water Inlet – 15mm 1/2" G
- Single water feed – pre-mix water (Mixing valve available to order if required, see ET-HCV)
- Water temperature - 1-50°
- Flexi hose - approx. 60cm long
- Sensor control cable from base of spout - approx. 1M long
- Transformer cable (if used) approx. 1M

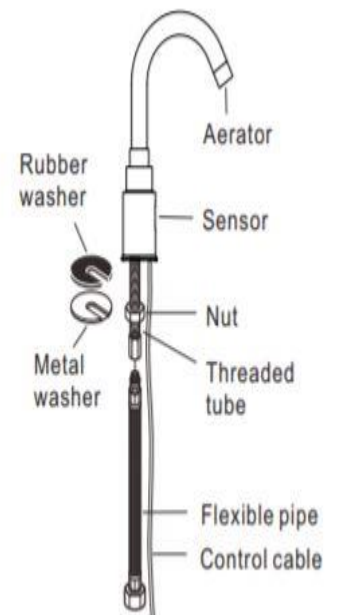

CONTROL BOX

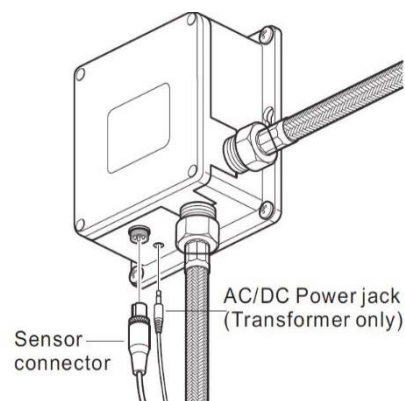
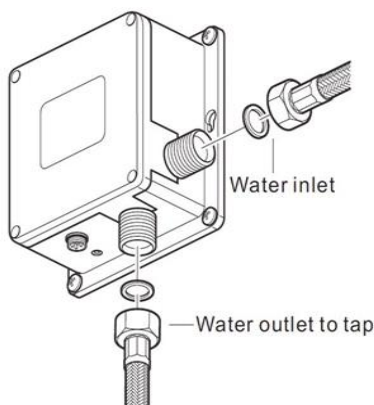

Contact Us:

Australia – 1300 530 883 or info@enviro-tech.com.au
 New Zealand – 0800 2 ENVIRO or info@enviro-tech.co.nz