

Specification Summary – ET2-GLD24.1

- 6 Star WELS
- Watermark
- Highly suitable for Commercial and Domestic use
- Basin or Deck mounted
- Hygienic no touch operation
- No fixed run time for maximum water saving
- Confirmation time of 1-2 seconds
- Auto off after 1 minute if sensor obstructed
- Self-adjusting sensor at water outlet
- Low sensitivity to reflective surfaces – more suitable for use with stainless steel sinks/troughs
- Sensor re-set function
- Battery only or mains power with battery back-up
- Water pressure range between 100-500kPa
- Water Inlet – 15mm ½" G
- Single water feed – pre-mix water (Mixing valve available to order if required, see ET-HCV)
- Water temperature - 1-50°
- Water hose from base of spout - approx. 1.1M
- Sensor control cable from base of spout - approx. 1.3M long (including control box connector lead)
- Transformer cable (if used) approx. 1M

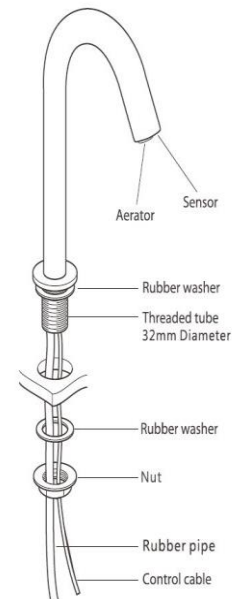

BENCH MOUNTED



CONTROL BOX

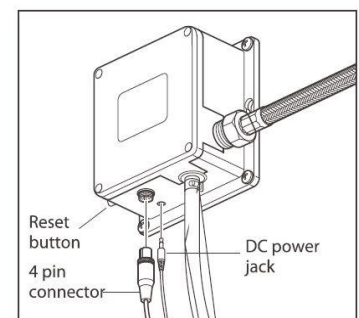
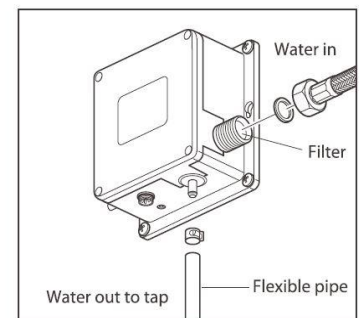

Contact Us:

Australia – 1300 530 883 or info@enviro-tech.com.au
 New Zealand – 0800 2 ENVIRO or info@enviro-tech.co.nz