

Specification Summary – ET2-SE

- Wall mounted sensor eye
- 6 Star WELS (when paired with an Enviro-Tech spout)
- Watermark
- Highly suitable for Commercial and Domestic use
- Ideal for use in all bathrooms and with stainless steel washplanes/sinks
- Hygienic no touch operation
- Front access mounting for easy installation
- Confirmation time of 1-2 seconds
- Standard eye - no fixed run time for maximum water saving (specify ET2-SE)
- Alternative option – as per standard eye and with additional swipe on/off setting (specify ET2-SE.2)
- Auto off after 1 minute if sensor obstructed
- Sensor distance set at 300mm (adjustable with remote control, purchased separately (ET2-SERC))
- Battery only or mains power with battery back-up
- Water pressure range between 50-500kPa
- Water Inlet – 15mm ½" G
- Single water feed – pre-mix water (Mixing valve available to order if required, see ET-HCV)
- Water temperature - 1-50°
- Sensor control cable - approx. 1.5M long
- Transformer cable (if used) approx. 1M

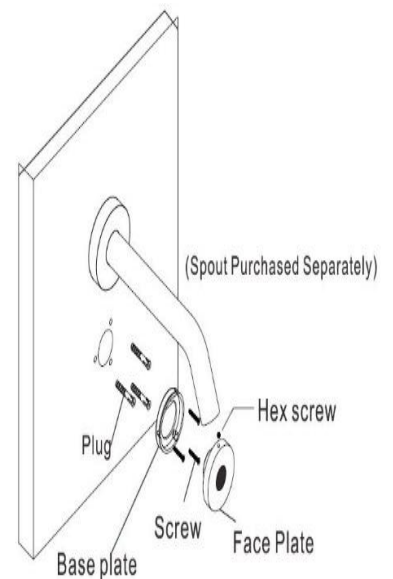

CONTROL BOX

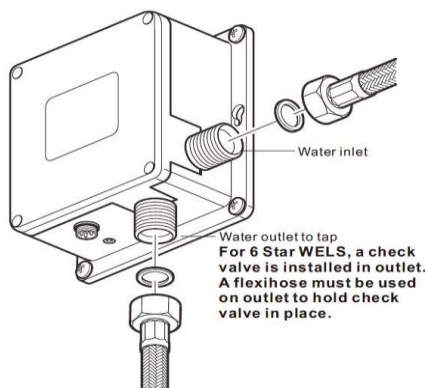

(NB. Hoses not supplied)

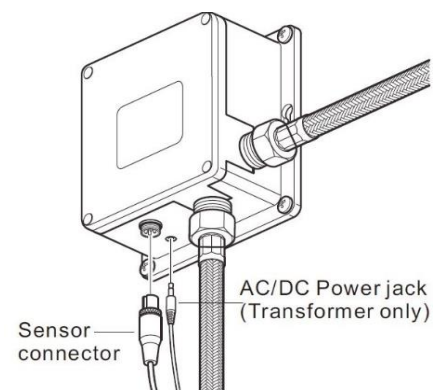

Contact Us:

Australia – 1300 530 883 or info@enviro-tech.com.au
New Zealand – 0800 2 ENVIRO or info@enviro-tech.co.nz