

Specification Summary – ET2-30.1

- 6 Star WELS
- Watermark
- Highly suitable for Commercial and Domestic use
- Deck mounted
- Tall classic 'r' spout at total height of 365mm
- Mid-point of sensor is 202mm from base of tap
- Ideal for use behind a deck mounted basin – check sensor height against basin dimensions
- Hygienic no touch operation
- Confirmation time of 1-2 seconds
- No fixed run time for maximum water saving
- Auto off after 1 minute if sensor obstructed
- Self-adjusting forward-facing sensor
- Normally suitable for use with stainless steel sinks/troughs
- Battery only or mains power with battery back-up
- Water pressure range between 100-500kPa
- Water Inlet – 15mm ½" G
- Single water feed – pre-mix water (Mixing valve available to order if required, see ET-HCV)
- Water temperature - 1-50°
- Flexi hose - approx. 60cm long
- Sensor control cable from base of spout - approx. 1M long
- Transformer cable (if used) approx. 1M

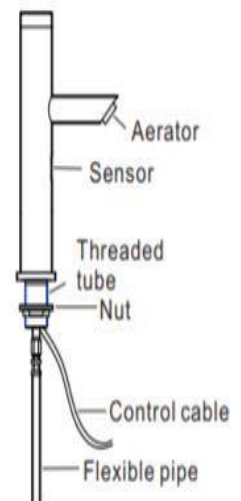

CONTROL BOX

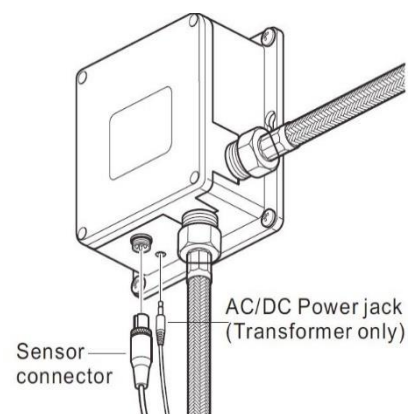
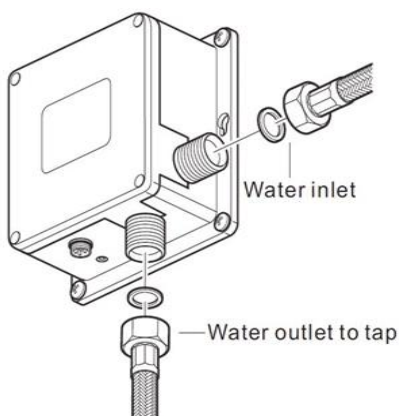

Contact Us:

Australia – 1300 530 883 or info@enviro-tech.com.au
 New Zealand – 0800 2 ENVIRO or info@enviro-tech.co.nz